

Operating Instructions



Operating Instructions



Operating Instructions

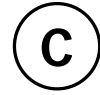

Model:

TB 100

TB 200

Equipment Parts

1. On\Off Switch
2. Ready Light
3. Binding Area
4. Cooling Stand
5. Binding Timer (TB 200 only)

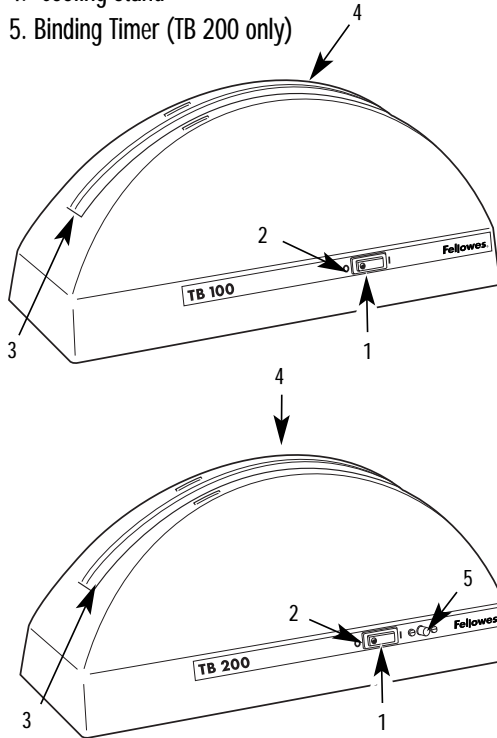

4. Insert sheets into thermal cover. Be sure all sheets are perfectly aligned and in contact with glue strip.
5. Place document in Binding Area.
NOTE: Index portion of cover should be in bottommost part of machine.
6. TB 100: Allow machine to bind document for 30-60 seconds.
TB 200: Press Binding Timer. Binding is complete when Timer sounds. Turn off Timer by pressing button.
7. Remove document from Binding Area. Gently tap document on tabletop to complete the binding cycle.
8. Allow finished document to cool vertically for 8-10 minutes by placing on Cooling Stand.
NOTE: Do not open finished document before cooling cycle completes. Glue must adhere to all pages.

Adding/Removing Sheets from Bound Document

Adding or removing pages from a bound document is possible, but not recommended.

ADDING PAGES

1. Place sheets to be added at their required position in the document.
2. Place document in Binding Area.
3. TB 100: Allow machine to bind document for 30-60 seconds.
TB 200: Press Binding Timer. Binding is complete when Timer sounds. Turn off Timer by pressing button.
4. Remove document from Binding Area. Again, gently tap document on tabletop to complete the binding cycle.
5. Allow finished document to cool vertically for 8-10 minutes by placing on Cooling Stand.
NOTE: Do not open finished document before cooling cycle completes. Glue must adhere to all pages.

Using the Binding Machine

1. Turn On\Off switch to "On" position.
2. Machine is ready to bind when Ready Light illuminates (approximately 1-2 minutes).
3. Using the table below, choose the correct thermal cover based on the total number of sheets to be bound:

Thermal Cover Size

# of Sheets	Inches	mm
1-30	1 $\frac{1}{8}$ "	3.2
31-60	1 $\frac{1}{4}$ "	6
61-90	3 $\frac{1}{8}$ "	9.5
91-120	1 $\frac{1}{2}$ "	12.5
121-150	5 $\frac{1}{8}$ "	15.5
151-180	3 $\frac{1}{4}$ "	20
181-200	1"	25

A

B

C

REMOVING PAGES

1. Place document in Binding Area.
2. TB 100: Allow glue to soften (approximately 1-2 minutes).
TB 200: Press Binding Timer. Binding is complete when Timer sounds. Turn off Timer by pressing button.
3. Remove selected pages laterally and rapidly.

4. Remove document from Binding Area. Gently tap document on tabletop to complete the binding cycle.
5. Allow finished document to cool vertically for 8-10 minutes by placing on Cooling Stand.

NOTE: Do not open finished document before cooling cycle completes. Glue must adhere to all pages.

Specifications

	TB 100	TB 200
Maximum Binding Length	13 inches (330mm)	13 inches (330mm)
Maximum Binding Capacity	200 sheets	200 sheets
Maximum Binding Diameter	1" (25mm)	1" (25mm)
Dimensions (LxWxH)	15-3/4 x 6-3/8 x 7-7/8" (400 x 162 x 200)	15-3/4 x 6-3/8 x 7-7/8" (400 x 162 x 200)
Weight	3lbs. (1.4kg)	3lbs. (1.4kg)
Warranty	1 year	1 year

Limited Warranty

Fellowes Manufacturing Company warrants all TB Model Binding Machines to be free from defects in material and workmanship for a period of one year from the date of purchase by the original consumer. The exception to this are the punching dies which are subject to wear. If any part is found to be defective during the warrant period, your sole and exclusive remedy will be repair or replacement, at Fellowes' option and expense, of the defective part. This warranty does not apply in cases of abuse, mishandling or unauthorized repair. ANY IMPLIED WARRANTY, INCLUDING THAT OF MERCHANTABILITY OR FITNESS FOR A PARTICULAR PURPOSE, IS HEREBY LIMITED IN DURATION TO THE APPROPRIATE WARRANTY PERIOD SET FORTH ABOVE. In no event shall Fellowes be liable for any consequential or incidental damages attributable to this product. This

warranty gives you specific legal rights. You may have other legal rights which vary from state to state. To obtain service under this warranty on machines purchased in the USA, return the machine prepaid to the address below. Please allow two weeks for processing.

Return with machine:

- Copy of original sales receipt.
 - A card stating your name, address, daytime telephone number, machine model and serial number, plus a brief description of the problem.
- For specific instructions on obtaining service under this warranty on machines purchased outside the USA, contact the appropriate location listed below.

Warrantor: Fellowes Manufacturing Company

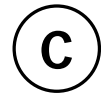

U.S.	1-800-955-0959
Australia	+ 6139-330-3211 (inside Melbourne) 1-800-331-177 (outside Melbourne)
Benelux	+ 31-3473-77988
Canada	1-800-665-4339
France	+ 334-789-12279
Germany	+ 4951-31-49770
Japan	+ 81-3-5496-2401
U.K.	+ 44-1302-885331

Fellowes 1789 Norwood Avenue, Itasca, Illinois 60143-1095 630-893-1600 Customer Service 1-800-945-4545 <http://www.fellowes.com>

Australia	Benelux	Canada	France	Germany	Italy	Japan	Poland	United Kingdom
Tullamarine, Vic	Vianen, NL	Markham, Ont.	Rennes, I-V	Garbsen, Han.	Camerano, AN	Tokyo	Warsaw	Doncaster, S. Yorks.

Part No.

© 2000 Fellowes Printed in U.S.A.